

URETHANE SPRING

ウレタンストックブロック(全長指定タイプ)

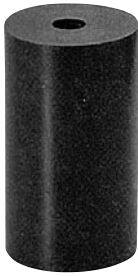

EL

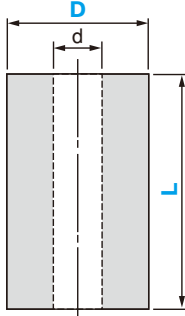

D	D	d	L
40	± 0.2	± 0.2	± 0.3
50	± 0.3	± 0.2	± 0.5
70			
90			
100	± 0.4	± 0.2	± 0.5
110			

硬度 ショア A90

●規格仕様

発注 No.		d	L 指定 1mm 単位
記号	D		
EL	40	14	15 ~ 200
	50		
	70		
	90	22	
	100		
	110		

	Order 注文例	形式 EL70 - 22 - 155
--	----------------------	------------------------------

	Delivery 納期	3 日目着 (又は 3 日目発送)
---	------------------------	----------------------