

DIE BUSHINGS

パンチガイドブシュ (ストレートタイプ)

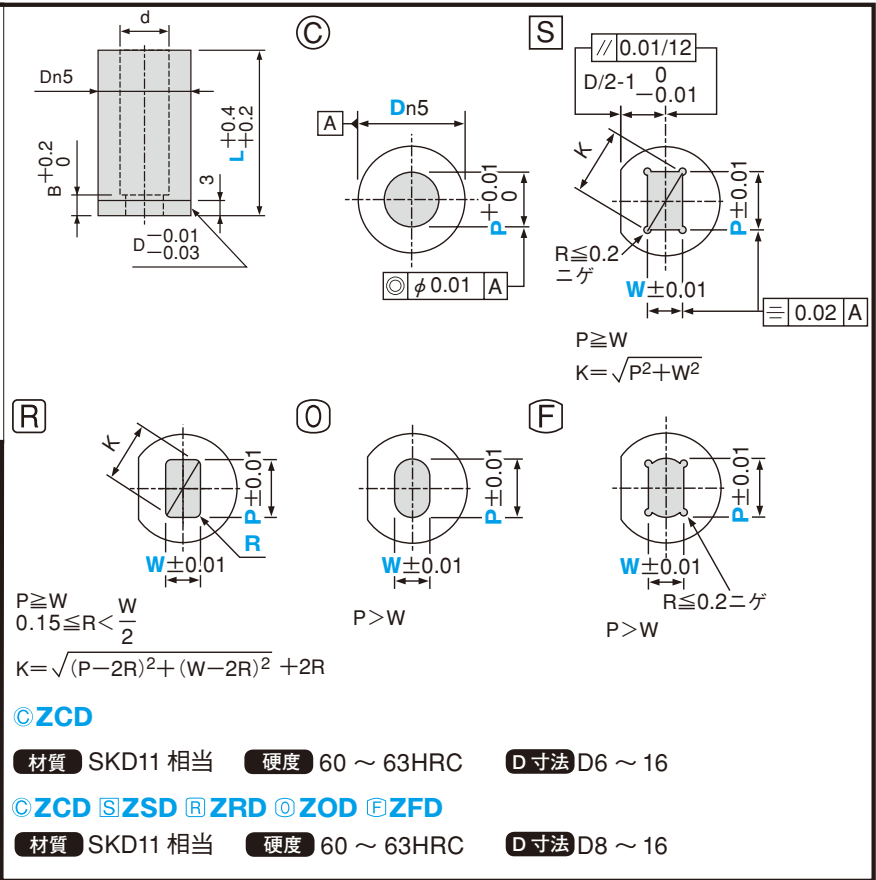



D 公差	
D	n5
6	+0.013 +0.008
8	+0.016 +0.010
10	
13	+0.020 +0.012
16	



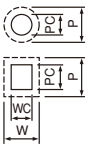

●規格仕様

カタログ No.	D	L	指定 0.01mm 単位				B	d
			◎	S R O F	R			
記号			min.P max.	P · K max.	P · W min.	R		
◎ ZCD	(6)	10 13 16 20 22 25	1.00 ~ 3.00	—	—	0.15 ~ W/2 未満 R のみ	3	3.4
S ZSD	8	10 13 16 20 22 25	1.00 ~ 4.00	4.00	1.00		4	4.4
R ZRD	10	10 13 16 20 22 25	2.00 ~ 6.00	6.00	1.20			6.4
O ZOD	13	10 13 16 20 22 25	3.00 ~ 8.00	8.00	1.50			8.4
F ZFD (SKD11 相当)	16	10 13 16 20 22 25	3.00 ~ 10.00	10.00	2.00		6	10.6

① : D(6) → D = (6) は◎形状(丸)のみの規格です。S R O F 形状はありません。

●追加工

▶追加工	型式	◎	ⓈⓇⓇⓇ
	PC WC	ガイド径変更 $\min: P > PC \geq \frac{P \cdot \min}{2} \geq 1.00$ 指定0.01mm単位 ① PC1.50~1.99の場合、 D13.16→B=4 になります。 $\max: P < PC \leq P + 0.2$	ガイド径変更 $\min: \frac{P}{W} > \frac{PC}{WC} \geq \frac{P \cdot W \cdot \min}{2} \geq 1.00$ 指定0.01mm単位 $\max: \frac{P}{W} < \frac{PC}{WC} \leq P \cdot K \max + 0.2$
	PKC	刃先径公差変更 $P + 0.01 \rightarrow +0.005$ ④ P < 1.00適用不可	刃先径公差変更 $P \cdot W \pm 0.01 \rightarrow +0.01$ ④ P · W < 1.00適用不可
	LC	全長変更 $10 \leq LC < L$ 指定0.1mm単位 (LKC・LKZ併用の場合0.01mm単位指定可)	

▶追加工	型式	◎	ⓈⓇⓇⓇ
	LKC	全長公差変更 $L + 0.4 \rightarrow +0.05$ $+0.2 \rightarrow 0$	
	LKZ	全長公差変更 $L + 0.4 \rightarrow +0.01$ $+0.2 \rightarrow 0$ ④ L (LC) < 16適用不可	
	KC	④ 廻り止め一面加工 ④ D3~6適用不可	 廻り止め 位置変更 指定1°単位
	WKC	廻り止め平行加工(2面) KC併用可 ④ D3~6適用不可 ④ L (LC) < 16適用不可	

	Order	形式D—全長—先端寸法—追加工
	注文例	例 ZCD10 — 20 — P5.0 —

	Delivery	4日目着
	納期	(又は4日目発送)