

厚板用ストレートパンチ (厚板用 Q 型パンチ)

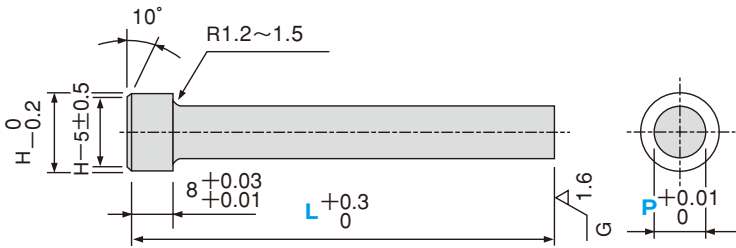







AQCH
 材質 SKH51 硬度 61 ~ 64HRC





AQCP
 材質 粉末ハイス鋼 硬度 64 ~ 67HRC

●規格仕様

カタログ No.		L										指定 0.01 mm 単位		H
記号	No.											min. Pmax.		
AQCH	4	40	50	60	70	80						3.00 ~ 4.00	9	
	5	40	50	60	70	80						4.00 ~ 5.00	10	
	6	40	50	60	70	80						5.00 ~ 6.00	11	
	8	40	50	60	70	80	90	100			6.00 ~ 8.00	13		
AQCP	10	40	50	60	70	80	90	100			8.00 ~ 10.00	15		
	13	40	50	60	70	80	90	100	110	120	10.00 ~ 13.00	18		
	16	40	50	60	70	80	90	100	110	120	13.00 ~ 16.00	21		
	20	40	50	60	70	80	90	100	110	120	16.00 ~ 20.00	25		
	25	40	50	60	70	80	90	100	110	120	20.00 ~ 25.00	30		

●追加工

追加工	型式	Spec.
	PRC	刃先側端面R加工 $0.3 \leq \text{PRC} \leq 1$ 指定0.1mm単位 ① $\text{PRC} \leq (\text{P}-0.2)/2$ ② PCC併用不可
	PCC	刃先側端面C面取り加工 $0.3 \leq \text{PCC} \leq 1$ 指定0.1mm単位 ① $\text{PCC} \leq (\text{P}-0.2)/2$ ② PRC併用不可
	PKC	刃先公差変更 $\text{P} \begin{matrix} +0.01 \\ 0 \end{matrix} \rightarrow \begin{matrix} +0.005 \\ 0 \end{matrix}$ ① P寸法0.001mm単位指定可
	LC	全長変更 $20 \leq \text{LC} < \text{L}$ 指定0.1mm単位 (LKC・LKZ併用の場合0.01mm単位指定可)

追加工	型式	Spec.
	LKC	全長公差変更 $\text{L} \begin{matrix} +0.3 \\ 0 \end{matrix} \rightarrow \begin{matrix} +0.05 \\ 0 \end{matrix}$
	LKZ	全長公差変更 $\text{L} \begin{matrix} +0.3 \\ 0 \end{matrix} \rightarrow \begin{matrix} +0.01 \\ 0 \end{matrix}$
	KC	ツバ部廻り止め一面加工
	WKC	廻り止め平行加工 (2面)
	KFC	廻り止め0°と角度指定加工 (2面) 指定1°単位 ② KC・WKC併用不可



**Order
注文例**

形式 No. - 全長 - 先端寸法 - 追加工

例 AQCH10 - 70 - P9.0 -



**Delivery
納期**

4 日目着
(又は 4 日目発送)